

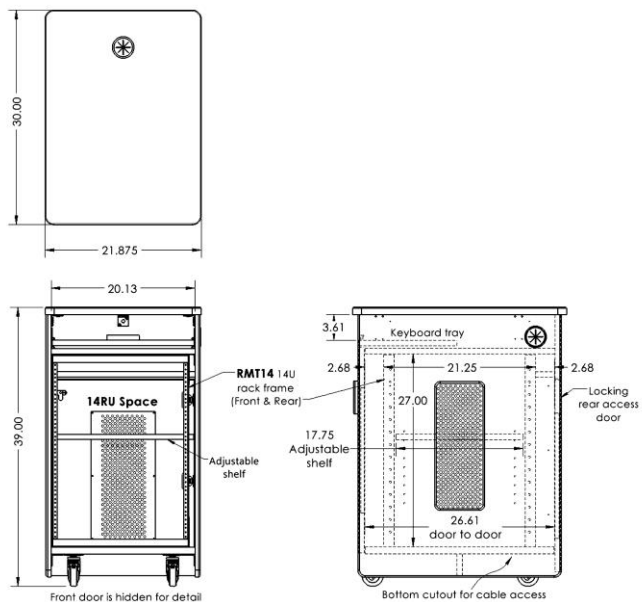

Link as modular to other main components of the PD51 Series using the optional **5104TP** Bridge below.



Convert to a left or right-hand Desk station using the optional **5104DE** Desk End below.



The **RK5105** is a Mobile Rack, ideal solution for distance education, electronic classrooms and corporate training sites. It features front and rear 14U Rack frame with adjustable shelf, a top surface to support monitors, laptops and room control systems, front and rear locking doors and keyboard tray.

Standard Features

- 21.875" W X 30" D work surface
- Cable access grommet on top and side panels
- Easy front and back access with metal vents
- Rack 14 spaces EIA compliant threaded rack frame (Front & Rear)
- Keyboard tray
- Interior adjustable shelf
- Ventilation provided through vents all around
- Heavy-duty casters for easy maneuvering (2 locking)
- Highly resistant thermowrap surface & body finish
- Ships assembled

Options

- **5104TP** Bridge Top (for modular options)
- **5104DE** Desk End (ADA complaint)
- **SH-FL-51** Folding side shelf kit
- **C900S** 15" - 24" Adjustable monitor arm
- **PLM1022** 10" - 24" Monitor mount
- **MM1232** 12" - 32" Monitor mount
- **MCB1925** 19" - 25" monitor/camera bracket
- **FM3** Count down timer/ clock
- **MIC-18** MX418C Shure Gooseneck microphone
- **LIGHT-18** Littlite Gooseneck
- **PB** Six outlet power bar with 10 ft. Cord
- **PC-PATCH** 2x 110AC, RJ45, Phone, 2x USB
- **SF-PB3** Surface mounted 3-outlet 120V power bar
- **CUB3** Round cable well
- **CUB4** Black-B/Silver-S Power Panel
- **CUB5** Round cable well (Black or Silver)
- **CUB8** Table top cable well
- **CUB22** 3 Module Power panel, Black (2x AC, 2x USB fast charging 3.2A)
- **CUBM3** 3 Module Power & Data panel, Black (2x AC, 1x Cat 6 port w/pigtail, 1x HDMI Port).
- **CUBM4** 4 Module Power & Data panel, Black (2x AC, 1x Cat 6 port w/pigtail, 1x HDMI Port).
- **CHGQIB** Wireless Charging Station, Black (UL, CE, Qi certified).
- **9031/9041/9052** Metal shelves/drawer (Check website)
- **9107** Lacing bar (19" long)
- **DIR9200-12** 12U Rack module
- **LEV4AX4** 4x Levelers for non-mobile applications
- **CUSTOM CUTOUT** Cutouts for electronics or other items specified by the customer

Specifications

Model: RK5105
Width: 21.875"
Depth: 30"
Height: 39"

Finishes:

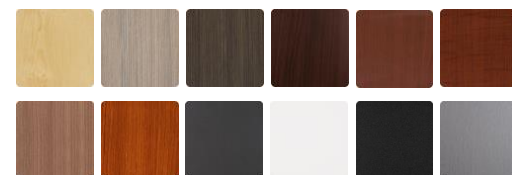

The information contained in this drawing is the sole property of Audio Visual Furniture International. Any reproduction in part or as a whole without the written permission of Audio Visual Furniture International is prohibited. We can build or modify stock configurations to suit customer specifications. Please contact us to discuss how this service can help meet your needs. Some quantity restrictions may apply. Specification subject to change without notice. Computers, cameras, monitors, etc. are shown to illustrate product usage and are not included unless otherwise noted.

The **PD51 Series** Podium and Rack Mobile Modular brings modern look and feel to educational and corporate training sites. Made with highly resistant thermowrap finish and designed for easy installation and flexible enough to arrange according to the choice and room spacing.

PODIUM AND RACK CONFIGURATION EXAMPLES

(Images shown in River Cherry-RCT finish. Stool and chair not included)

Components: PD51, 5104TP & RK5105

39" height work surface Mobile Station & rack
94.875"W x 30"D



Audience View

Components: PD5103, 5104TP & RK5106

Podium & rack with ADA compliant desk work surface
88.125"W x 30"D (30" height desk top)



FEATURES & BENEFITS

- Front and rear lockable doors provide security and quick access to multimedia equipment.
- Rack rails or Rack frame included for equipment mounting.
- Metal perforated plates all around keep the equipment ventilated and cool.
- Heavy-duty casters for easy maneuvering (2 locking) or levelers for non-mobile applications.
- Custom cutouts available for accessories, electronics or other items specified by the customer.
- Highly resistant thermowrap surface & body.
- **Customizable Work surface for PD51, PD5103 and PD5107.** Front panel of the console can be easily removed or the complete console to make use of the entire work surface.



- 58" Worktops only available for **PD51** Station that can be easily attached according to choice. Folding side shelf and other components can be installed on either side of the Station.
(Folding side shelf cannot be used along with 5102TP Top)

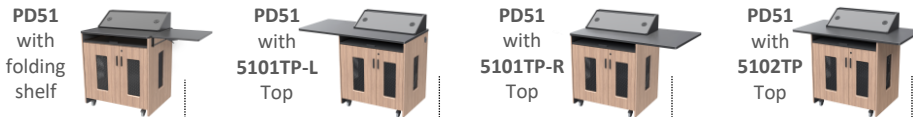

- Main components can be converted to a mobile desk station using the **5104DE** Desk End. This Desk is reversible to allow installation for left or right-hand applications.



STANDARD FINISHES

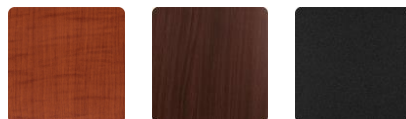

Other finishes are available. Check website.

MAIN COMPONENTS



PD51 Mobile Station
36.5"W x 30"D x 47"H



PD5107 Dual Rack Station
42.75"W x 30"D x 47"H



PD5103 Podium
29.75"W x 30"D x 47"H



RK5105 14U Mobile Rack
21.875"W x 30"D x 39"H



RK5106 12U Mobile Rack
21.875"W x 30"D x 30"H

OPTIONAL ACCESSORIES



5101TP-L 58" Top Left overhang
(Fits on PD51 only)



5101TP-R 58" Top Right overhang
(Fits on PD51 only)



5102TP 58" Top Double overhang
(Fits on PD51 only)



5104TP Bridge Top
36.5"W x 30"D x 17"H



5104DE Desk End (ADA compliant)
(For left or right-hand application)
36.5"W x 30"D x 30"H



SH-FL-51 Folding Side Shelf Kit
21"W x 23.75"D

Visit our website for individual component information, features and other available accessories.

The information contained in this drawing is the sole property of Audio Visual Furniture International. Any reproduction in part or as a whole without the written permission of Audio Visual Furniture International is prohibited. We can build or modify stock configurations to suit customer specifications. Please contact us to discuss how this service can help meet your needs. Some quantity restrictions may apply. Specification subject to change without notice. Computers, cameras, monitors, etc. are shown to illustrate product usage and are not included unless otherwise noted.